

Product No. FX-3680-3

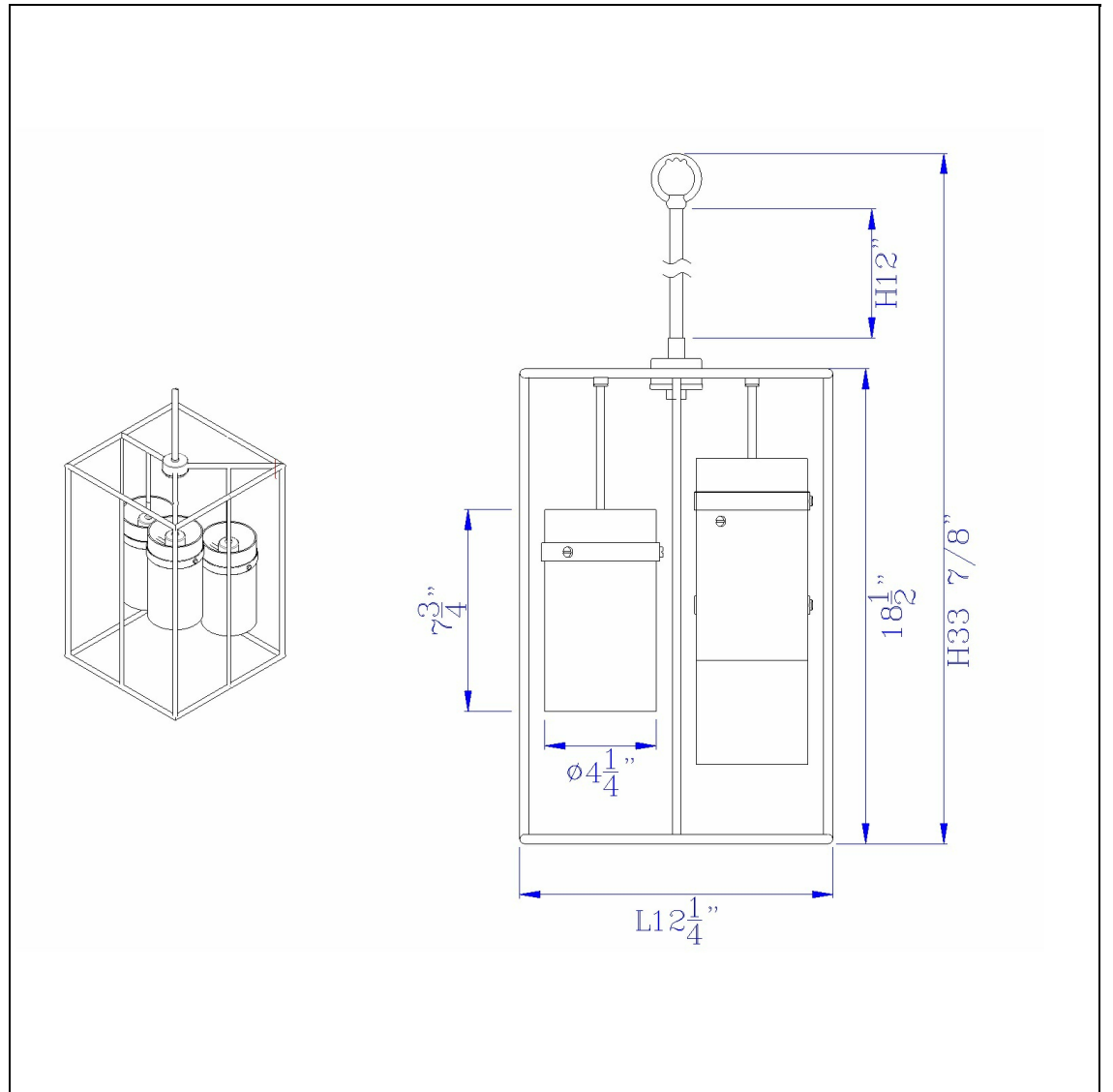

Description

60W X 3 Cremona Glass Pendant Fixture
(Edison Bulbs Not included)
Durable Metal and Glass Construction
Ships in One Carton
Hand Blown Glass
Includes 6 Feet of Chain
Includes 6 Feet of Chain
33.88" Heigh Metal Pendant with Glass
Shades in Black/Antique Brass Finish

Technical Specifications

UPC	020193067284	Shade Top1	4.25
Wattage	60WX3	Shade Bottom1	4.25
CRI	N/A	Shade Side	7.75
Lumen	N/A	Carton 1 Dimensions	22.50 x 10.80 x 10.80
Switch Type	Hardwired	Carton 2 Dimensions	0.00 x 0.00 x 10.80
Bulb Base	E26	Package Dimensions	L: 10.80 W: 10.80 H: 22.50
Number of Lights	3		
Color	Black/Antique Brass		
Base Color	Black/Antique Brass		